

The multi-talent.
Speedmaster CX 75.



We accompany you. On your journey into the digital future.

For over 160 years, HEIDELBERG® has prided itself on having a vital edge. That's why print shops all over the world trust our expertise and experience. Now they are also looking to us to help with the digital transformation of their business. As a reliable partner and technology pioneer, we create added value. We do so by providing printing systems that use Push to Stop technology for autonomous, top-quality production and data-supported services. Services that are paving the way to the Smart Print Shop – the digitally connected, intelligent, highly automated print shop of the future. For better decisions, higher productivity, and enhanced efficiency.

We laid the foundations years ago by creating presses that were connected online and analyzing the data to boost performance and availability. Today, we offer you an entire ecosystem for digitizing value creation at print shops. As well as smart services such as predictive maintenance. You also benefit from trendsetting business models such as pay-per-outcome. Under this model, HEIDELBERG provides all the necessary equipment, software, consumables, and services. You simply pay for the number of sheets printed – for “productivity on demand” that can be flexibly adapted to your requirements. We call this “Simply Smart”.





Contents

04
Speedmaster CX 75

06
**Optimizing OEE increases
profitability**

08
**The HEIDELBERG User Experience
on the Speedmaster**

09
The facts at a glance

14
UV finishing

16
Flexibility for all requirements

18
10 clear benefits

19
Your dialog with HEIDELBERG



The all-in-one solution. **Speedmaster CX 75.**

The Speedmaster® CX 75 is a real multi-talent. It is based on the innovative technology of the Peak Performance class of the Speedmaster XL 75. The inclusion of the sheet travel concept with double-diameter impression cylinders opens up a wide range of applications and a large variety of substrates.

Experience undreamt-of performance. With Push to Stop, the efficiency of print production (OEE) can be raised to a level that has been difficult to achieve in the past. Assistance systems revolutionize your job changes with comprehensive, time-optimized automation. Push to Stop and the implementation of artificial intelligence offer you a unique user experience (UX): autonomous and navigated printing across the entire printing process. Intelliline can be used to visualize the respective machine states.

Machine operation is now easier than ever – the HEIDELBERG User Experience of the Speedmaster will inspire you.

The compact Speedmaster CX 75 can be perfectly integrated into almost every pressroom thanks to its small footprint. The ergonomic press concept permits quick and easy operation. It lets you produce exactly what your customers want, cost-effectively and sustainably.

Greater success in the market for small and large printing companies.

Optimizing OEE increases your production profitability.

With the Speedmaster, HEIDELBERG offers you the most highly automated and most intelligent Speedmaster yet. The smart machines in the series take advantage of the huge spectrum of digital possibilities for outstanding productivity and a significant increase in overall equipment effectiveness (OEE). The clear focus on operator-independent performance on the Speedmaster raises the Push to Stop philosophy from HEIDELBERG to a whole new level.

From the smart printing press to the smart print shop to the smart printing industry

Digitization is changing the printing industry. HEIDELBERG is making use across the board of the far-reaching optimization potential of digital technologies in the enhancement of its Speedmaster series with the objective of smart integration within the print shop and as part of a smart printing industry, where all stakeholders – print buyers, creatives, printing companies, service providers, and suppliers – are connected.

The future of industrial printing

Integrated communication along the entire process chain, paired with intelligent automation – this is the future of modern print production, whether for smaller businesses or large industrial printing companies. Intelligent production reduces complexity and speeds up processes autonomously. The key to this is digital connectivity with the Prinect® Workflow.

OEE – the key performance indicator for productivity

Overall equipment effectiveness is an important key performance indicator for assessing how effectively a production system is operated in practice. It is made up of the factors of availability, performance, and quality. The average OEE across all format classes is currently around 20 percent, and even the Speedmaster XL 106 from the Push to Stop generation, with an average OEE of 27 percent, still offers considerable improvement potential, since the OEE that can realistically be achieved is much higher.

This is proven by Speedmaster presses operating with an OEE of 50 percent and up. The average productivity is expected to double in the coming years. With up to 90 million printed sheets a year, the first Speedmaster users are already showing what is possible.

Increasing overall equipment effectiveness (OEE)

Significant reduction of process-dependent and operator-dependent downtimes through Push to Stop.

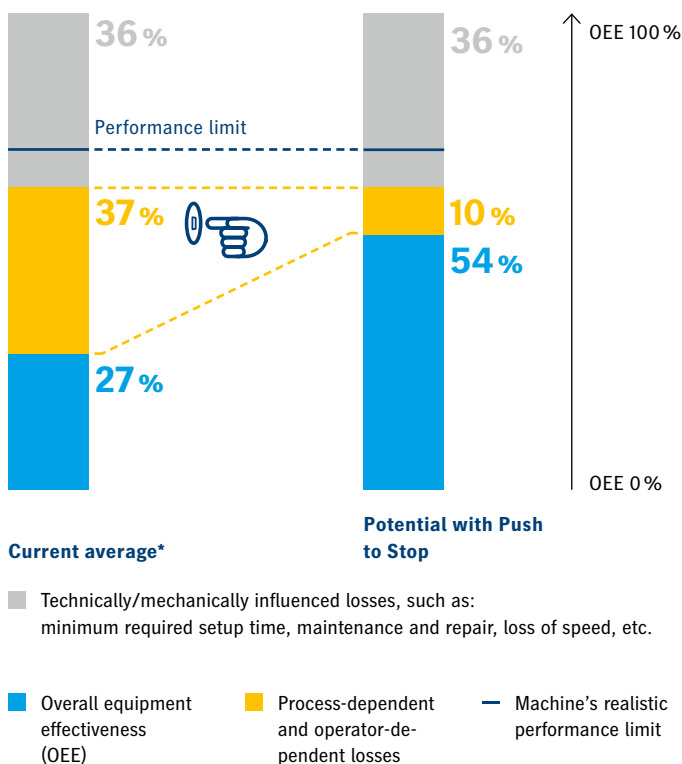

*OEE analysis 2020 using the example of a Speedmaster XL 106 and a run of 4,600 sheets

Exploiting potential: focusing on the yellow bar

In order to increase the OEE of the machines, existing improvement potential must be activated. Around half of this potential is tied to technical aspects (gray bar in graphic). However, technical improvements will not necessarily result in success – only if the organizational aspects are improved at the same time. The other half of the potential relates to processes and operators (yellow bar in graphic). This is precisely where HEIDELBERG concentrates its activities.

Process improvements and operator-independent solutions with Push to Stop have a direct effect on the OEE

Improvements that act on the yellow bar, in other words on the processes and operators, have a direct influence on the OEE. This is where the greatest potential lies. With Push to Stop, more extensive process automation, and intelligent assistance systems, the Speedmaster presses enable even more comprehensive navigated and autonomous printing.

Speedmaster: clear focus on operator-independent performance through intelligent automation.

- Close automation gaps
- Intelligent assistants for navigated printing
- Digital integration and use of digital data
- Potential of AI ensures optimal use of resources and highly effective production

The machine's intelligence minimizes the operator's influence on performance. Productivity is increased, processes are sped up, and become plannable and reproducible. The operator is navigated through the processes at a modern and attractive workstation, and in this way is better equipped to handle the greatly increased day-to-day requirements. Push to Stop on a new level – for optimized overall equipment effectiveness on all Speedmaster models.

Printing has never been so easy.

The HEIDELBERG User Experience.

Immerse yourself in the world of the HEIDELBERG User Experience (UX): Rethought and clearer than ever before, it sets standards for the user experience on the Speedmaster. The Prinect Press Center® XL 3 with the Speedmaster Operating System simplifies operation through one-of-a-kind navigation and innovative assistance systems, thus ensuring predictable results and increased performance.



A clear view for quality and precision

HEIDELBERG UX is the holistic and intuitive operation of all HEIDELBERG touch points. Intelligent assistants and a uniform user interface reduce complexity and simplify production processes.

Focus on you, the user

The Speedmaster Operating System with intuitive touch control turns the convenient control of the Speedmaster into an experience. Settings can be called up with a click, and the scalable operation can be flexibly adjusted in accordance with the requirement profile. Intuitive operator guidance, innovative gesture control, and integrated help functions eliminate lengthy searches.

The Speedmaster Operating System delivers fast, simple and navigated use of all your machine's functionalities.

The most intelligent Speedmaster yet – assistants for key processes

Integrated assistance systems make your work easier. They look after routine tasks and ensure reproducible results.

Push to Stop – reliable performance day after day through one-of-a-kind navigation and automation

Navigated printing with Push to Stop is possible on all Speedmaster presses. Intellistart® defines all the steps required for the job change without any operator intervention and provides maximum transparency across all active and queued processes. Intelliguide® simulates the time-optimized sequence live and, if necessary, also includes the steps to be executed manually.

Everything at a glance

The Wallscreen XL completes the operator's unique navigation for the highest performance demands. Intellirun, the dynamic production view, automatically shows the operator the right display at the right time and provides intelligent information on the current production status. Thus, Intellirun supports you not only

Outstanding characteristics.

The facts at a glance.



Highlights:

- Individually configurable with four to seven printing units, optionally with coating unit and various DryStar® systems for UV and conventional applications.
- Highest print quality at a maximum printing speed of 15,000 sheets per hour.
- One of the narrowest presses in this format class combined with the best ergonomics thanks to its innovative operating concept and excellent accessibility.
- High flexibility thanks to a wide range of substrates, from lightweight paper through to rigid cardboard (0.03 mm – 0.80 mm).
- Optionally available in 605×750 mm (23.82 × 29.53 in) sheet format; for more repeats on the printed sheet.
- High preset capability for format settings, substrate thickness, ink presets, and speed compensation.
- Prinect Press Center XL 3 control station with intuitive operator guidance system Intellistart 3 for fast and process-oriented setup and extremely user-friendly operation.
- The highly automated Preset Plus feeder looks after the relevant format and air settings, for reduced makeready times and steady sheet travel.
- Sheet transfer system with Venturi technology for gentle and controlled sheet travel, from the feeder pile to the delivery pile, with a wide range of substrates.
- Shorter makeready times thanks to the reliable and fully automatic AutoPlate Pro plate changing system. Precise plate feeding and identification for an accurate, fast register. The operator can perform other tasks while the plates are being changed.
- Quick and thorough washing of the inking unit and blanket and impression cylinders. The Wash Assistant determines the fastest and most efficient washup program for each job on the basis of the job data.
- AutoProtect fully automatically supplies unused printing units with roller protection liquid.
- Fast changeover between conventional and UV inks due to additional washing circuit.

The Speedmaster CX 75 is the flexible straight-printing press in the 50 × 70 (19.69 × 27.56) format range – an all-rounder built for the future. It offers a modern press concept with innovative solutions. The result is a versatile and economical press, perfectly tailored to the requirements of your customers and to your success.



- Fast changes between conventional and UV inks thanks to the additional washing circuit.
- The coating unit with chamber blade system ensures uniform coating application. Easy screen roller and coating changes further enhance the flexibility. The Saphira® anilox rollers, manufactured in-house using the patented PLP – pulse laser process, ensure homogeneous coating application with low coating consumption.
- Perfect drying with thick substrates and high speeds thanks to the delivery extension and DryStar Combination with round-nozzle technology.
- Spectrophotometric color measurement systems help to ensure a reliable and standardized printing process.
- Preset Plus delivery with optimal, precise sheet deposit and touchscreen for easy operation.
- Preset values provide a fast way of achieving easy, reproducible production with consistently high print quality.
- The carton kit allows stable production of cardboard boxes even at high production speeds.

→ You can find more about the details of your Speedmaster here:
heidelberg.com/cx75/technical-data

Prinect Workflow.

One for all!

Prinect Business and Prinect Production merge all print production stages into a single, end-to-end process – from costing to prepress, press and postpress right through to invoicing. Reduce complexity, boost your profits: With Prinect, you can access all workflow functions while only paying for the volume you actually produce, rather than for individual licenses.

→ Find out more:
heidelberg.com/en/prinect



Perfect piles thanks to the Preset Plus delivery ensure smooth postpress operations.



The coating unit in combination with the DryStar dryers permits outstanding coating and drying results, even at high speeds.



The generous space between the printing units in combination with folding steps permits quick and easy operation.

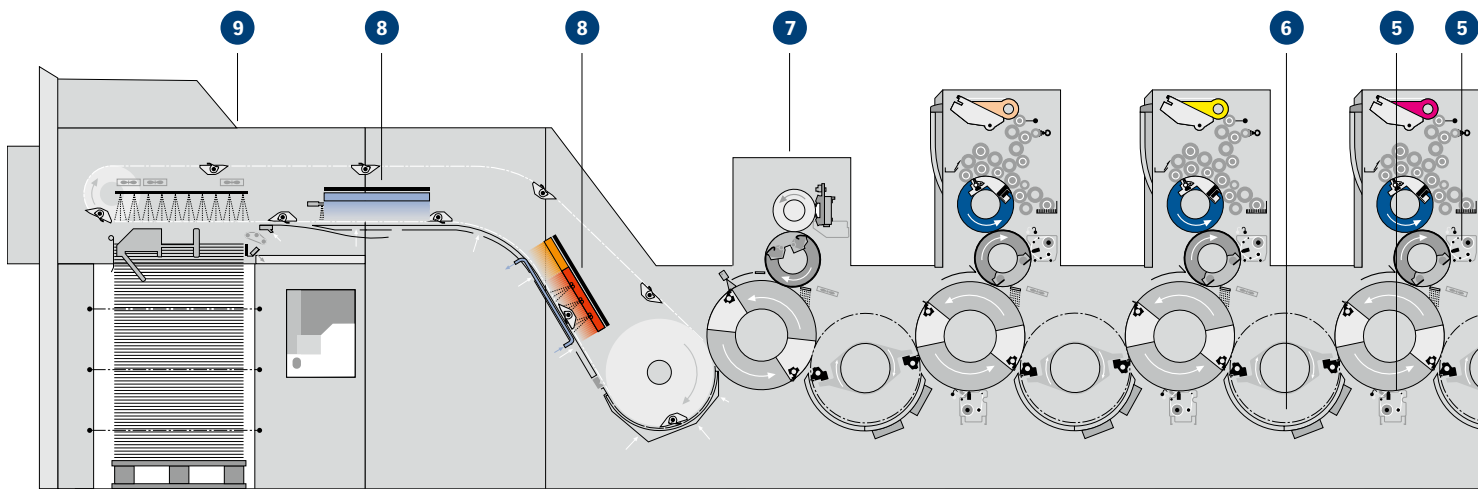

Speedmaster CX 75-5+L. The press shown is a sample configuration. Some of the equipment features mentioned are optional.

1 Antistatic technology

- StaticStar minimizes electrostatic charging, especially with lightweight materials, and optimizes the sheet travel for high production speeds.

2 Preset Plus feeder

- Precise alignment of the sheet due to central suction tape and pneumatic pull lay as the launchpad for optimal production.

3 Inking unit and dampening unit

- The inking and dampening system offer responsiveness and color stability. Relevant functions can be remote-controlled, including the short-path inking function with minimal ink consumption.
- The Vario function avoids hickeys during the production run.

4 Plate changing system

- AutoPlate Pro permits fully automatic, staggered plate changes within the shortest time.

5 Washup devices

- Extremely quick washing with outstanding results for rubber blanket and impression cylinders with the blanket washup device.
- Easy and ergonomic installation and removal.
- Easy and fast replacement of the washup cloth.

6 Sheet travel

- The sheet transfer system with presettable Venturi technology and a printing-nip blowing unit ensure gentle sheet travel from the feeder to the delivery.
- Double-diameter cylinder transfer for a wide range of substrates.
- The biggest cylinder diameter in this format class ensures optimum sheet travel and excellent accessibility.

7 Coating unit

- The coating unit with chamber blade system and a wide range of coating supply and screen roller technologies enable outstanding coating results for diverse applications.
- Automated coating plate changes ensure quick, easy coating plate and coating blanket changes as well as reduced setup times.
- Register settings can be made in a wide setting range at Prinect Press Center XL 3.



Very gentle sheet travel thanks to double-diameter impression cylinders and Venturi technology.

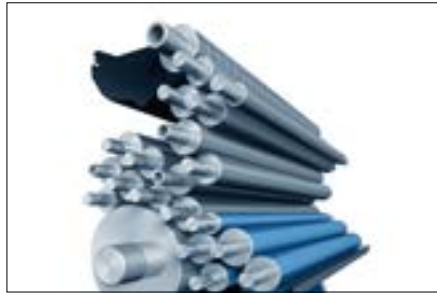

The inking unit and dampening system permit stable coloring over the entire production run.



The Preset Plus feeder provides the best launchpad for successful production.

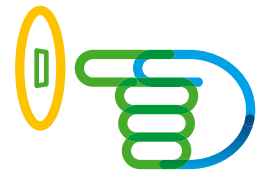
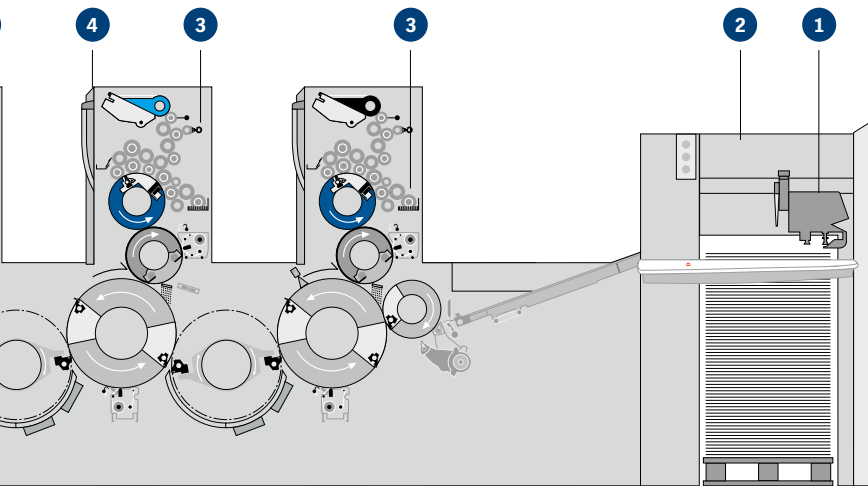

Push to Stop.
The key to the
Smart Print Shop.

8 Dryer system

- Delivery drying units and UV interdeck dryers permit flexible drying downstream of the printing or coating units.
- The various DryStar systems are optimally matched to the sheet travel and ensure the best drying results as appropriate to the application.
- Tool-free removal of the dryer systems for good accessibility.

9 Preset Plus delivery

- All relevant settings are automatically adopted from the presetting data.
- High printing quality in different applications is made possible by the free positioning, the option of an inclined position, and the easy removal of the brake modules.
- The presettable delivery air system with honeycomb grid ensures optimal distribution of the air flows and precise delivery of different materials.

→ You can find more about the details of your Speedmaster here:
heidelberg.com/en/cx75

HEIDELBERG contracts.

Contract packages as individual as your requirements.

You benefit from a combination of HEIDELBERG best-in-class products. Our Lifecycle and Subscription packages help you keep your machines running at their best.

→ Find out more:
heidelberg.com/contracts



Modern working environment on the Prinect Press Center XL 3 with wallscreen and multi-touchscreen for optimal sheet coordination.



Intelliline offers one-of-a-kind assistance and transparency at the machine and navigates you through any manual steps required.

during automated job changeover, but also throughout the entire production process. All production steps are supported by an up-to-date overall view.

The **Intelliline LED-based navigation support** extends this logic to the machine. The resulting expansion of the Intelliguide process display in Intellistart 3 provides a color visualization of the unit status on the operator and drive sides via Intelliline. You can keep an eye on everything at all times and are prompted when intervention is required.

The result: A new era of navigated and autonomous printing with Push to Stop. Productivity without interruptions with fully automatic job changeover – from the last to the first good sheet and the start of production.

Perfect data and color management with Prinect

The Prinect Press Center XL 3 links the printing press to the print shop's Prinect Workflow. Job data can be transferred and also made available in an automatically defined sequence. Job data can be transferred and also made available in an automatically defined sequence. The production data is returned fully automatically. This enables you to benefit from excellent data management, one-of-a-kind presettings, up-to-date production data, and informative reports.

Various Prinect color measurement systems are available to you for optimal, reproducible color stability and minimum paper waste. As the most economical system in its class, Prinect Easy Control is the ideal entry point into spectral measuring technology. Other options include the powerful Prinect® Axis Control® in the Prinect Press Center XL 3 as well as the highly automated spectral measurement system Prinect Inpress Control® (Prinect Inpress Control® 3). All color measurement systems are perfectly integrated into the workflow. The color library provides the reference values for color control with every job and also serves as the basis for the color reports.

The flexible Press Center Mobile web app provides you with a quick overview of all Speedmaster machines. All relevant information is available on the move and in real time. The Production Screen visualizes important production and process data and thus optimizes the workflows in your print shop.

Simply – fast – reliable: the HEIDELBERG UX on the Speedmaster CX 75

Experience the HEIDELBERG UX on the Speedmaster CX 75 also. Every time you operate a component you are experiencing the Peak Performance concept. From the seamlessly ergonomic design, to the pioneering touchscreen control panel, the simple handling of the washup devices to the unique preset functionality, the Speedmaster CX 75 delivers an unparalleled user experience.

The future is bright.

UV finishing.

Bright results, short drying time, wide variety of substrates. UV-finished print products stand out thanks to their brightness, their feel, and their short throughput times.

What sets UV printing apart is its high productivity. UV-curing inks and coatings can go into postpress faster, which means no more waiting times and shorter delivery times. Storage space can also be reduced, since there is no longer any need to store semi-finished products. UV printed products provide a way to broaden your service portfolio for your customers.

The Speedmaster CX 75 with UV technology opens up new areas of business for you. You have even greater flexibility in the choice of substrate available to you, since plastics or natural and recycled papers can also be processed with exceptional brightness.

DryStar UV – outstanding performance in commercial and packaging printing

DryStar UV technology offers the perfect solution for print shops looking to explore the benefits of UV on their Speedmaster CX 75. DryStar UV reveals its strengths in equal measure in commercial printing and in label and packaging printing, even with short runs. With DryStar UV you benefit from a wide range of applications in terms of substrates, inks, and coating types.

DryStar LE UV – for increased energy efficiency

DryStar LE UV (Low Energy) uses special, highly reactive UV inks and coatings with a very energy-efficient curing process. Optimum coordination of the lamp technology to the press ensures extremely efficient energy use. Compared with conventional UV systems, DryStar LE UV technology requires comparatively lower investment while offering almost the same range of applications.



DryStar LED Pro – environmentally friendly technology for the future

DryStar LED Pro also delivers fast throughput times with the help of this future-oriented technology. You benefit from maximum energy efficiency and ozone-free production with minimal radiant heat within the press. With DryStar LED Pro, you get a perfectly dry sheet through the precise focusing of the light and the optimal distance from the sheet travel. No power is consumed in standby mode (makeready times, washing times) thanks to the Instant On/Off system. Auto Format Setting adapts the dryers to the paper format. This means that only those diodes that are required for the sheet format are switched on. Another advantage is the much longer lifetime of the LEDs compared with lamp technology.

All drying systems are perfectly matched to the features of the Speedmaster CX 75 and fully integrated into the press and the remote system.

Your press can be prepared for UV right from the factory. In addition to the UV delivery dryers, interdeck dryers whose positions can be freely selected are also available.

➔ **You can find more about the DryStar UV technologies here:**
heidelberg.com/en/starsystem

Machine and markets.

Flexibility for all requirements.

The Speedmaster CX 75 is the all-rounder that best equips you to meet your customers' needs. You benefit from the wide range of substrates and high level of automation of the press – factors that enable you to offer your customers an extensive product range and maximum flexibility.

The multi-talent

The Speedmaster CX 75 is the ideal press for customers that process a wide range of substrates. Whether traditional advertising materials or products from the area of packaging printing, you can rely on the Speedmaster CX 75.

The Speedmaster CX 75 is the perfect press for print shops that offer a wide range of applications. Its high level of flexibility means that you can comprehensively meet your customers' different requirements. It also offers consistently high print quality, various finishing options, an ergonomic operating concept and a high level of automation that is tailored to the daily demands of a print shop. Other advantages are the small footprint thanks to the narrow design of the Speedmaster CX 75 as well as the many configuration and equipment options.

Commercial printing

Success here demands an efficient production process that reduces costs and therefore increases cost efficiency.

The Speedmaster CX 75 is the highly productive straight-printing press for almost all applications. It is extremely flexible, enabling you to use a wide variety of different materials like natural papers or coated and shiny materials.

The press also offers you a wide range of finishing options like gloss and matt coating as well as spot and drip-off coating. With innovative drying technologies, you can make the most of these advantages in both conventional and UV printing.

With short runs, you benefit from automatic switchover made possible by accepting the preset values. This minimizes your makeready times and at the same time lowers your costs. The Speedmaster CX 75 is also the ideal press for getting started in packaging printing.

Label Printing

Lightweight substrates are predominantly used in the production of labels. Not a problem for the Speedmaster CX 75. With the StaticStar® anti-static package, you can process thin materials and foils with ease. Another advantage is the availability of a larger format (605×750 mm, 23.82×29.53 in), which makes it possible to have more labels on the sheet.

The combination of the sheet guide with Venturi technology, high-performance sheet brake and delivery air system in the delivery achieves reliable and precise placement on the pile for quick and easy finishing.



Packaging printing

The Speedmaster CX 75 lets you produce many applications cost-effectively in the growing packaging market. Short runs of small packagings, for example for local products, are often required. The Speedmaster CX 75 demonstrates its versatility once more here, especially in combination with the larger 605×750 mm (23.82 × 29.53 in) sheet format. This enables more repeats to be placed on the sheet. The cylinder concept with double-diameter impression cylinders allows you to process thick substrates with ease.

Coating application and drying as well as UV technology reduce your throughput times. Coordinated dryer systems ensure optimal drying results with minimal energy consumption – even at high speeds and with high color assignment.

In Speedmaster CX 75 configurations with coating unit, the single extended delivery permits optimal drying results, even with heavy grammages and high production speeds, from a small footprint.

Leader in the printing process.

10 clear benefits.

Makeready

0 min.

additional makeready time when changing format or substrate due to fully automated preset functionalities from the feeder to the delivery.



100 %

Time saving for the operator thanks to AutoPlate Pro.

Savings of up to **100** hours per year – selection of the most **suitable wash** program by the Wash Assistant.

Productivity

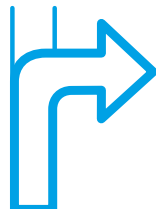

Navigated printing

with Intellistart 3! Full transparency and automatic processes improve the OEE in the pressroom.

Maximum speeds of up to **15,000 sheets** per hour for all materials, from lightweight paper up to cardboard.

Inking-up right from the **first pull!** Perfect interaction of **Color Assistant Pro**, **Color Fast Solution** and **Prinect measurement systems**.

Operation

One of the narrowest presses

in its format class.

Keep an eye on everything, even with complex job changes, thanks to the **innovative operator guidance system** with **Intelliguide** and **Intelliline**.

Release jobs for printing with just

2 clicks.

Ergonomic design for ideal accessibility and best ease of use.

Simply get in touch. Your dialog with **HEIDELBERG.**



We hope this brochure has inspired you. Our aim is to make you even more successful in the future, so feel free to contact us with your questions and suggestions. We're only ever an e-mail or phone call away.

We look forward to hearing from you!

Whether you're just curious or have specific things you'd like to ask, simply send an e-mail with your questions, requests, or comments to

➔ [**info@heidelberg.com**](mailto:info@heidelberg.com)

or use our contact form at

➔ [**heidelberg.com/info**](https://heidelberg.com/info)

If you prefer to use the phone, your local contact is waiting to hear from you. You'll find the phone number you need on the web page for your country.

➔ [**heidelberg.com/contact**](https://heidelberg.com/contact)



Your direct access to the digital world of HEIDELBERG, including our international distributors, newsletter registration options, and social media channels. Simply use your smartphone to scan the QR code.

[**heidelberg.com/dialogue**](https://heidelberg.com/dialogue)

Publishing information

Heidelberger Druckmaschinen AG
Kurfuersten-Anlage 52 – 60
69115 Heidelberg
Germany
Phone +49 6221 92-00
Fax +49 6221 92-6999
contact@heidelberg.com
Further details at:
heidelberg.com

Production note

Image credits: Heidelberger Druckmaschinen AG
Platemaking: Suprasetter
Printing: Speedmaster
Finishing: Stahlfolder
Consumables: Saphira

Printed in Germany**Trademarks**

HEIDELBERG, the HEIDELBERG logotype, AxisControl, DryStar, Inpress Control, Intelliguide, Intellistart, Prinect, Prinect Press Center, Saphira, Speedmaster, Stahlfolder, StaticStar and Suprasetter are registered trademarks of Heidelberger Druckmaschinen AG in the U.S. and other countries. All other trademarks are property of their respective owners.

For details on the emissions of the Speedmaster CX 75, please visit us at [heidelberg.com/emissiondetails](https://www.heidelberg.com/emissiondetails)

Liability for contents

The contents of this brochure have been prepared with great care. No warranty or liability is accepted for the correctness, completeness, or accuracy of the information. There is no guarantee or warranty that the customer will be able to achieve the values and numbers (e. g. relating to the function and performance of the machine and the software) specified in the brochure. The information provided is based on ideal conditions and proper use of the machine and the software. Achieving these values and numbers depends on a variety of factors and circumstances that are outside the control of HEIDELBERG (e. g. machine settings, technical conditions, ambient conditions, raw materials and supplies used, consumables used, standard of care and maintenance of the machine, expertise of the operator, meeting the respective system requirements, etc.).

Version Jan 2024